

# *X6000*



[www.shacman.com](http://www.shacman.com)



YouTube



Facebook



Wechat



# Loading, Leading

Long-distance standard load transportation

## Cab

### Platform

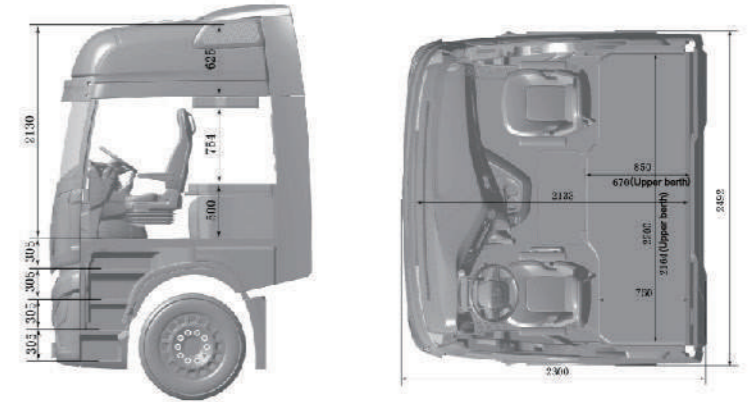

• Extended high-roof wide-body cab

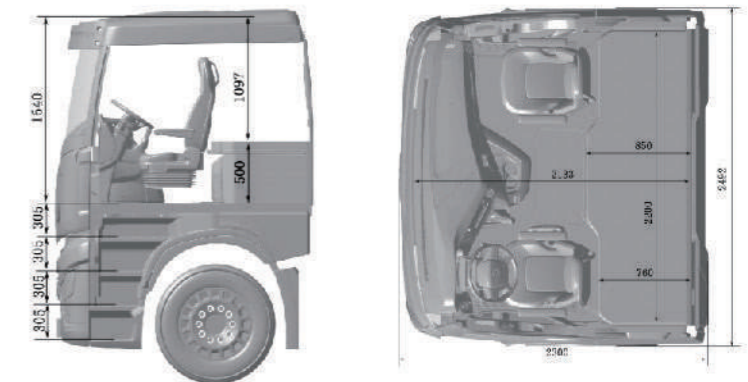

• Extended flat-roof wide-body cab

\*Left-hand drive or right-hand drive options available.  
Compatible with both fiberglass and metal bumpers.

# CONTENTS

05  
Efficiency

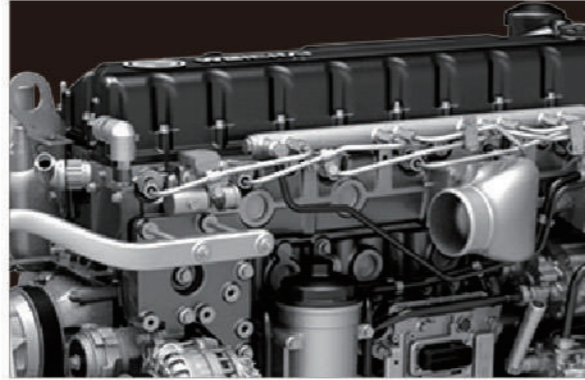

11  
Comfort

19  
Security



23  
Intelligence

33  
Reliability



37  
Smooth Ride



# Efficiency

**An outstanding economic planner**

Great ideals are achieved step by step;  
Tremendous profits are derived from every penny saved.

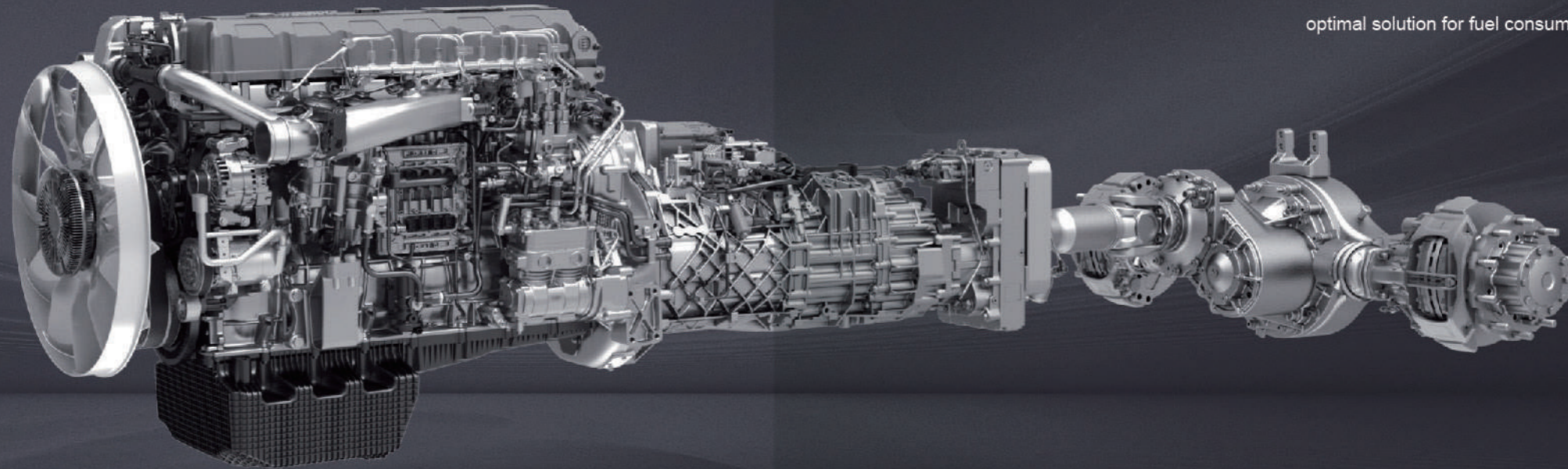

The renowned SHACMAN Golden Power Train has been upgraded again.

With top-level power technology in the industry, X6000 implements the optimal solution for fuel consumption and emissions.

### Efficient Air Intake System

Good at breathing, help in Burning

- Tangential intake air filter: super clean air intake
- Whole process air dehumidification system
- Low intake resistance: rated air flow of 2300m<sup>3</sup>/h

### Efficient Power Source Engine

Surging power

- Low revs, yet high power

Every drop of, make good use of

- Smart boosting technology
- High-efficiency fuel injection technology

Smart temperature adjustment system

- Based on real-time vehicle data, achieving efficient cooling

### Efficient Precision AMT Gearbox

Efficient transmission gear technology

- Refined processing gear with a transmission efficiency of 99.7%

Modular shift structure

- Reliable operation, easy maintenance and replacement

### Efficient Transmission Axle

13 ton efficient drive axle

- High precision KC bearings, 97.2% transmission efficiency

### Efficient Predictive Power Control

Road condition recognition, integrated decision-making

- Environmental recognition with high-precision maps
- Predictively adjusting vehicle power scheduling
- Low fuel consumption decision-making

## Facing the wind, leading the wind

### SHAC streamlined cab

- 0.454 vehicle drag coefficient, 2.7%-5.3% fuel saving improvement

### Dual-guided airflow design

- Underbody deflector & Infinitely adjustable top deflector



## Mastering thermal energy means mastering energy efficiency

- Fully enclosed flexible air resistance plate
- Asymmetric intercooler
- Integrated multi-channel radiator
- Large 63m<sup>2</sup> cooling module
- Curved ring fan

Under the integrated control of the VCU, the vehicle achieves a synergistic linkage of the thermostat, water pump, and fan. This dynamic control ensures the engine consistently operates within its optimal temperature range, thereby maximizing fuel efficiency.

# Comfort

## A home away from home

During a long journey, halt in a right place. As the distance from home grows progressively farther, yet always indulging in the comforting familiarity.





#### Cozy to sit in, smooth to drive

- Comfortable shock-absorbing seat: electric heating & air suspended
- 12 Comfort Features: both sides armrest, shoulder adjustment, one-touch release backrest, etc.

#### Cozy steering wheel, cozy control feeling

- Infinitely adjustable steering wheel
- 100mm telescopic stroke
- 38° maximum angle travel

#### Controls right at your fingertips\*

- Arrangement of the gearshift lever
- Integrated gear shifting and switch design

\*The shift lever is only available for AMT models

#### Dual-screen smart display, informative and entertaining

- Large display intelligent vehicle terminal
- Large LCD dashboard with 3 display style (Classic, Tech, Sport)

#### Focused when quiet

- Fully cab enclosed design: Sealing performance is 30% better than the industry average, with an idle environment of only 49.8dB, providing an immersive experience similar to a library.

#### Easy to get on the cab

- Hidden two-level flip pedals
- Two-level handle



**Mobile Cozy Home**

- Passenger hidden work table
- 40L double-compartment refrigerator
- 850mm soft sleeper
- Bedside reading lamp
- 1000L large storage space
- 2500KW inverter power supply
- Electric sunroof
- Multiple type-A/C charging ports (12V and 24v)

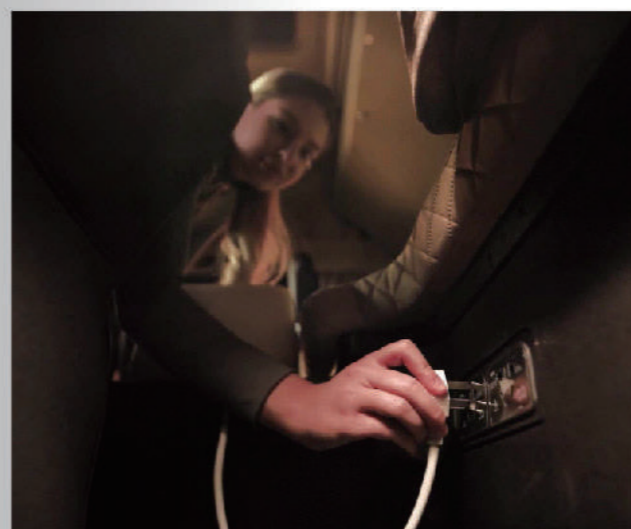

**Independent Warm Air System\***

- Specialized air heating path
- 4KW heating power
- Timing control
- Warm air even when the vehicle is turned off

\*Exclusive to cold regions.

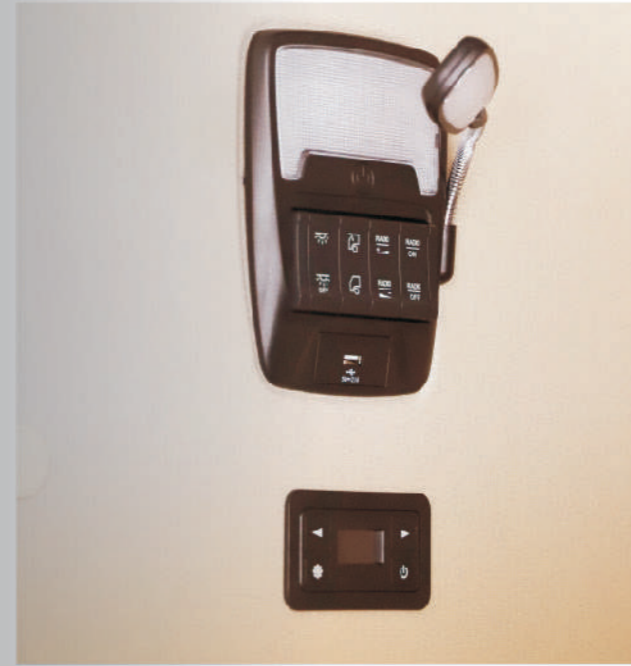

# Security

**A reliable broad shoulder**

Imagining every solitary journey, where there is always a broad and comforting shoulder to lean on.





#### Brand new platform, SSA top-level vehicle body

- H-type load-bearing longitudinal beam
- High-strength A-pillar
- Collapsible vehicle body suspension technology
- Compliant with ECE R29 03 collision regulations

#### Urgent emergencies, calmly braking

- Whole vehicle disc brakes
- 1.3MPa top-level system pressure: braking response time reduced by 0.2 seconds\*
- Industry-leading EBS system
- Dynamic main and auxiliary brake linkage: dynamic adjustment of the ratio between cylinder brake and retarder brake to maintain optimal braking performance

\*Compared to the main competitor

#### Light up the unknown

- Full LED lighting
- Broad night vision: high beam distance  $\geq 160\text{m}$ , low beam distance  $\geq 30\text{m}$

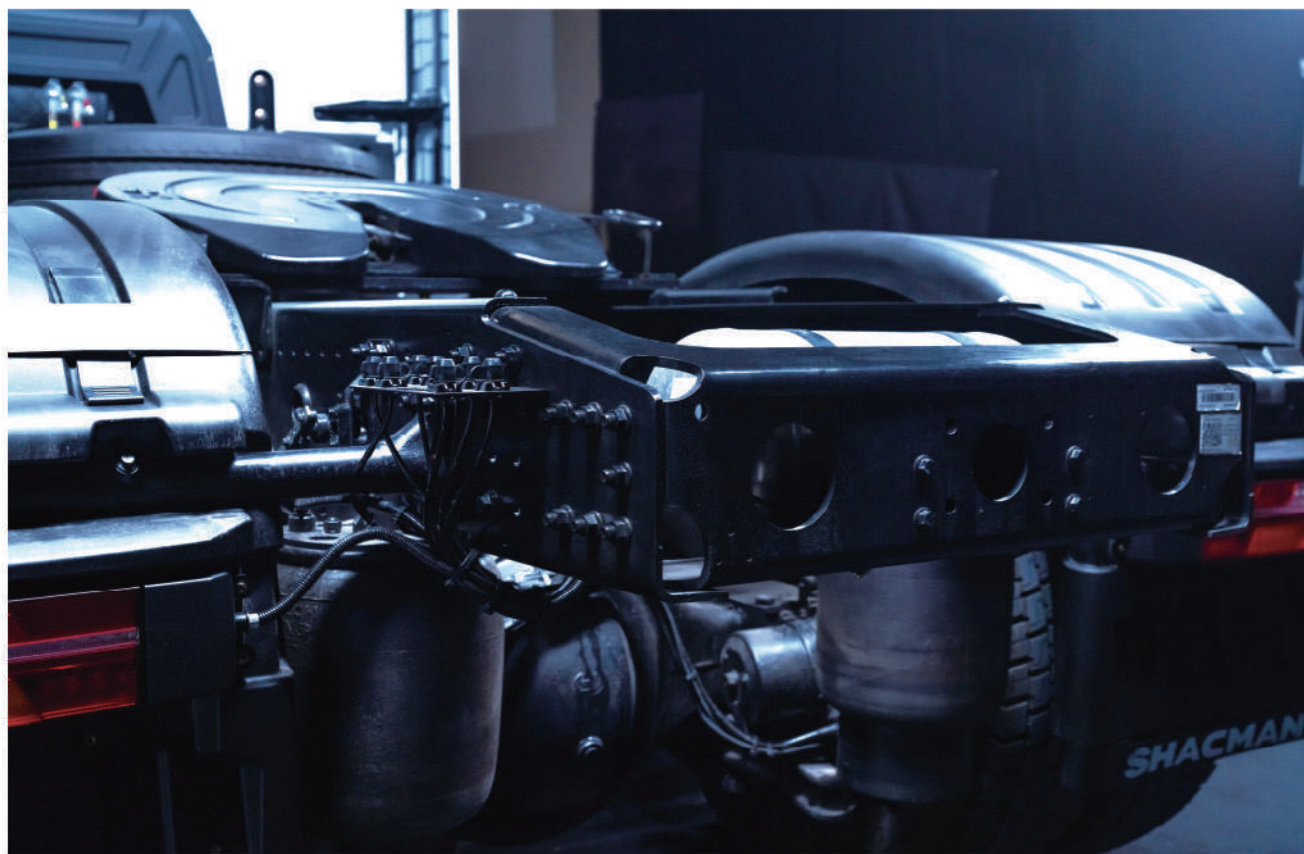

# Intelligence

**A wise contemplator**

This ruminative companion will always be able to consider everything beforehand.



## AI-CARE ADAS (advanced driving assistance systems)

Follow the guide, drive with ease

- S-Pilot: the comprehensive intelligent driving assistance system makes your journeys easier
- LDWS: when the vehicle deviates from the lane, a timely reminder is issued
- FCW: when the vehicle is too close to an object in front, a timely reminder is issued
- ACC: set the speed and distance, reduce driving fatigue and stress
- AEB: front danger detection, automatic emergency braking
- A series of smart safety features: EBS, ESC, ASR, HAS





## AI-CARE ASAS (advanced safety assistance systems)

Knowing the environment, knowing oneself

### When its time to take a break

- Careful gaze: the A-pillar smart eye real-time captures driver's state and timely send reminders
- 24/7 focus: active infrared camera, normal operation at night

### Holographic imaging, recognizing the real world

- 360° panoramic view
- 128 Gb storage card with 72 hours of HD video storage
- Adaptive dynamic perspective: smart scene switching perspective to reduce blind spots in the field of view
- Low-light camera: clearer at night

### Best tire condition, best driving experience

- Smart constant pressure tire system: significantly reduce fuel consumption and shorten braking distance
- Smart tire pressure and temperature warning system: real-time alarm for abnormal pressure and temperature

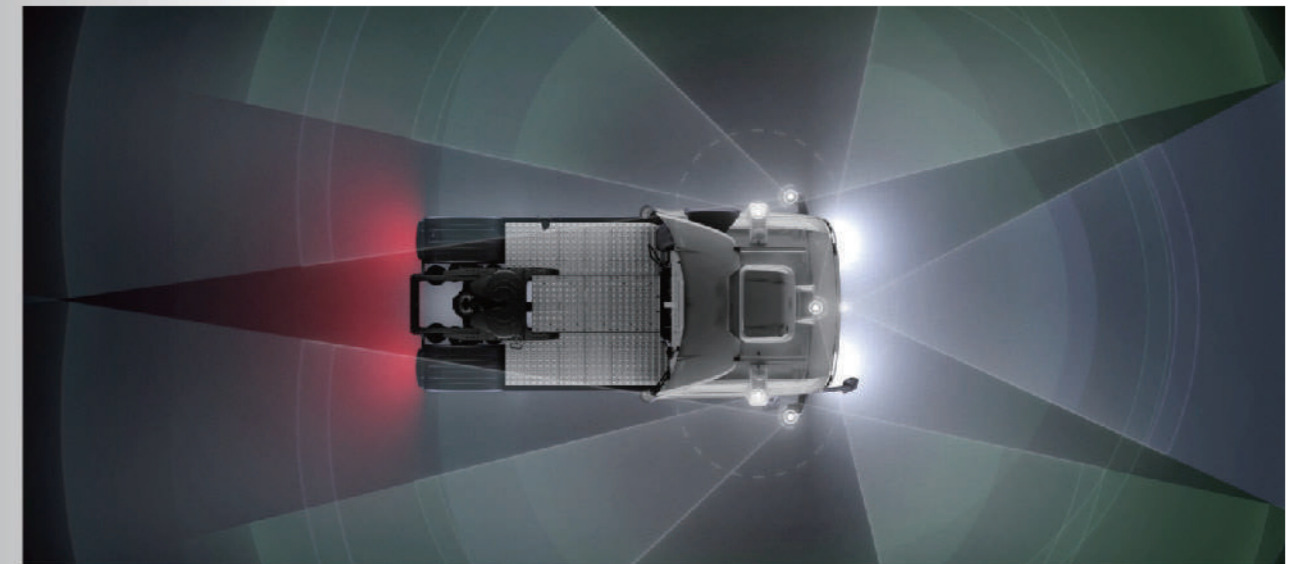

## AI-CARE AOAS (advanced operation assistance systems)

Automation, simplification

### Surreal, imperceptible start

- PEPS system: approach to unlock and leave locked, just have your key in the pocket
- Remote key: one button for lock/unlock doors, one button for raising/lowering windows

### Never look back, no matter when

- Electrically rearview mirror: 8° two-dimensional electric adjustment
- Electrically heated rearview mirror: heat for 8 minutes, defrost 75%
- Smart rearview mirror adjustment: safer reversing, wider vision

### Facing the storm with composure

- Smart wiper: rainfall and speed perception, optimal auto mode
- Smart lighting: environmental information perception, auto headlights control





## SHACMAN LINK

Keep your truck in control

---

Remote Operation: Vehicle positioning, remote self-diagnosis, engine warm-up, cabin temperature pre-conditioning, etc.

Online Services: Fleet management, real-time monitoring, one-click repair request, maintenance reminders, etc.

## Journey Doctor

Peace of mind on the road

---

By dynamically monitoring parameters such as oil quality, temperature, brake clearance, and battery power, 6000 series equipped with Journey Doctor can keep track of the health status of systems including power, steering, braking, and power supply in real-time, achieving early warning of abnormal conditions and providing real-time push notifications for maintenance and service solutions.

# Reliability

**Confidence forged in the crucible**

Refined by trial, the human spirit finds its grace;  
while rigorously validated, the vehicle secures its enduring place.



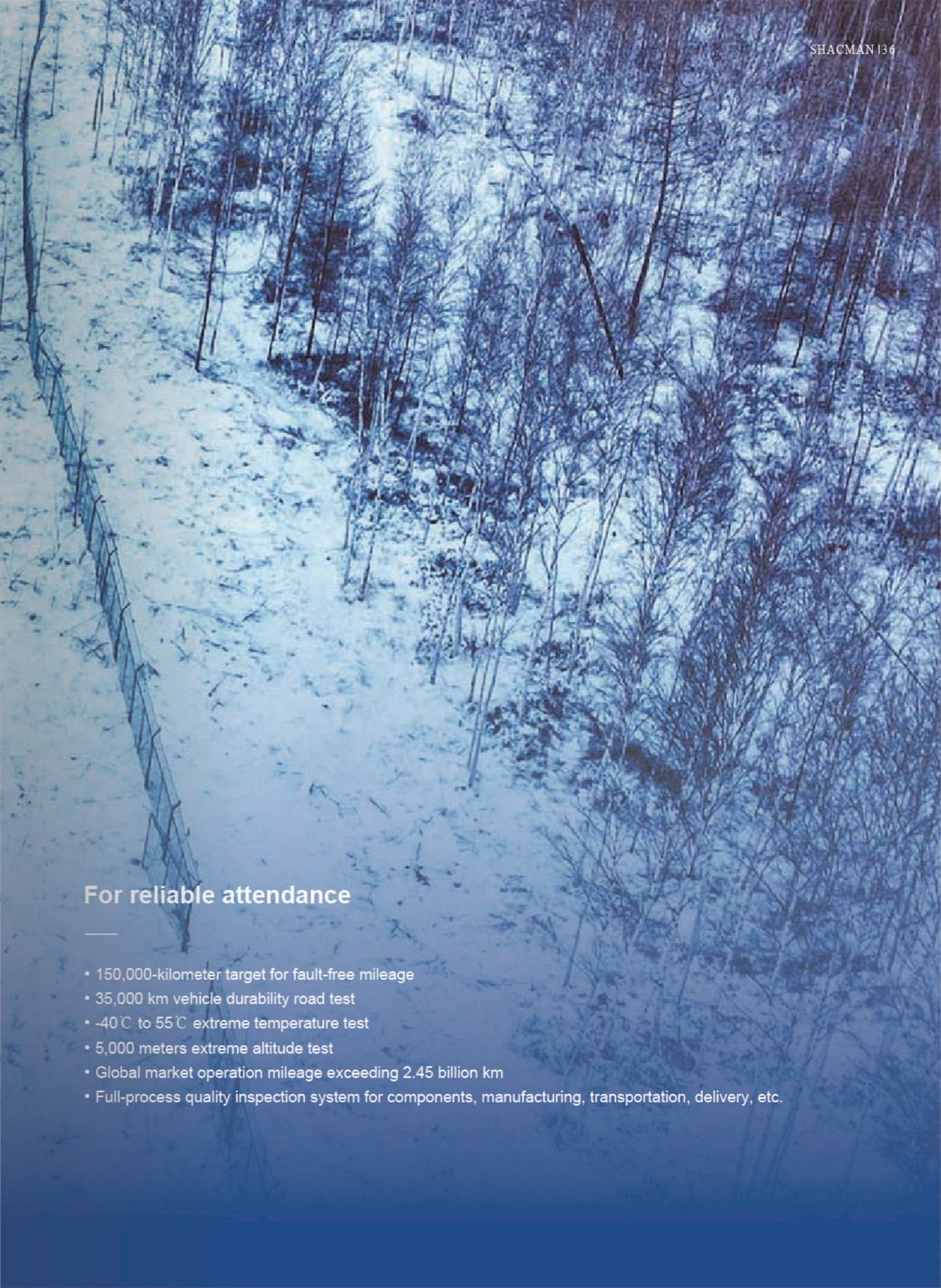
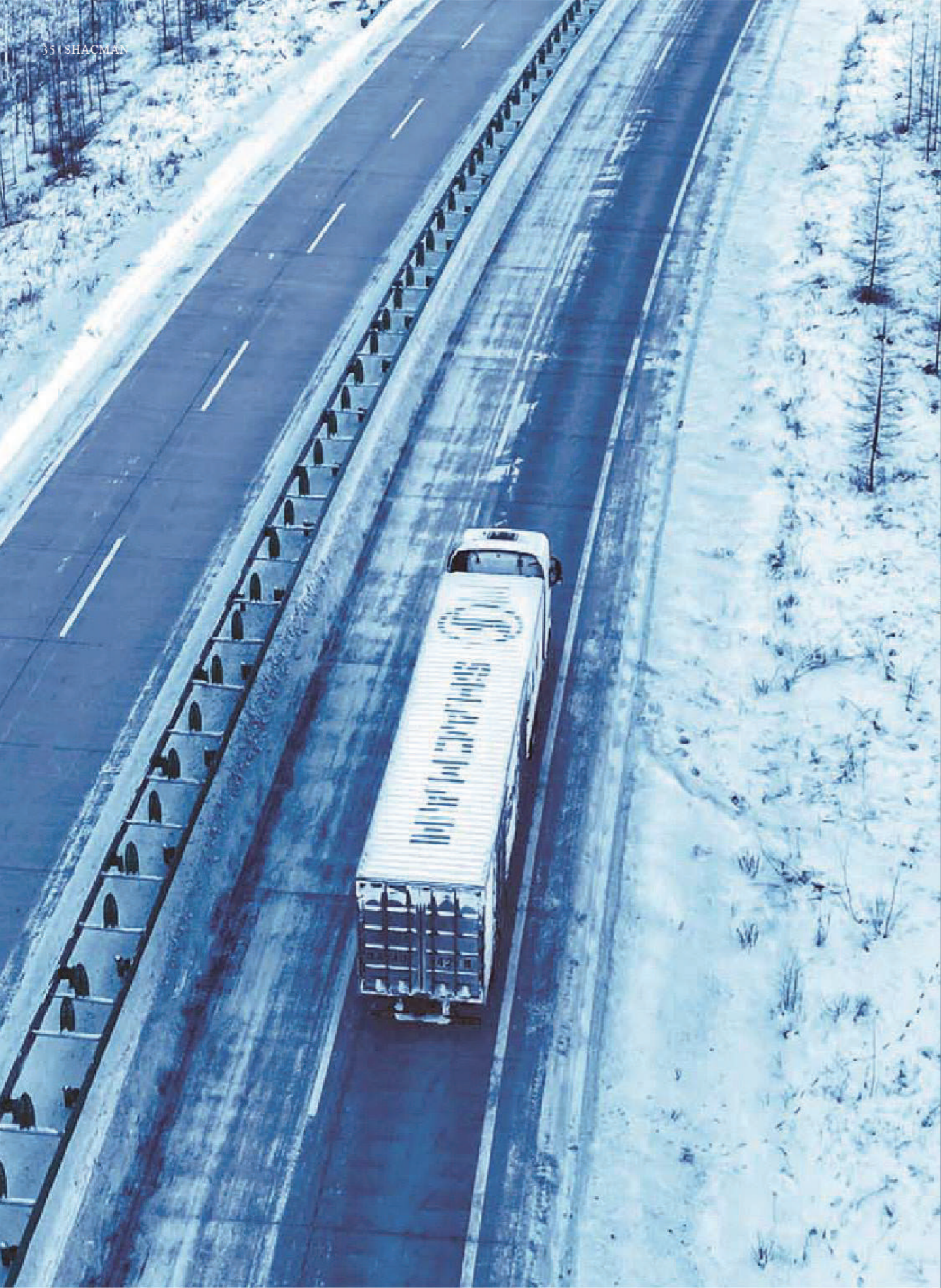

### For reliable attendance

- 150,000-kilometer target for fault-free mileage
- 35,000 km vehicle durability road test
- -40°C to 55°C extreme temperature test
- 5,000 meters extreme altitude test
- Global market operation mileage exceeding 2.45 billion km
- Full-process quality inspection system for components, manufacturing, transportation, delivery, etc.



# Smooth Ride

The steady joy

Having grown tired of traversing jarring paths, it is time to relish in the comforting embrace of stability and joy.

## Flexible support, dynamic balance

### Air Magic Carpet:

#### Twist spring type rear air suspension

- Dynamic vehicle height adjustment adapts to different road conditions
- 60kg lighter compared to the stable rod air suspension
- Effectively reduce road impact for protecting the safety of goods

#### Four-point air suspension of cab

- Powertrain vibration isolation rate increased by 30%
- Effectively reduce road bumps for a smooth drive

#### Customized tire tread

- Longitudinal pattern front wheel & block pattern rear wheel
- Comprehensive improvement of tires in driving, anti-slip, braking, heat dissipation, and wear resistance

### Steady Fast Turn:

#### Dynamic speed ratio linear steering technology & lateral stiffness synergistic control

- Maximum lateral acceleration of 0.6g and less than 6° vehicle body side tilt when turning
- 30% increase in lateral stability

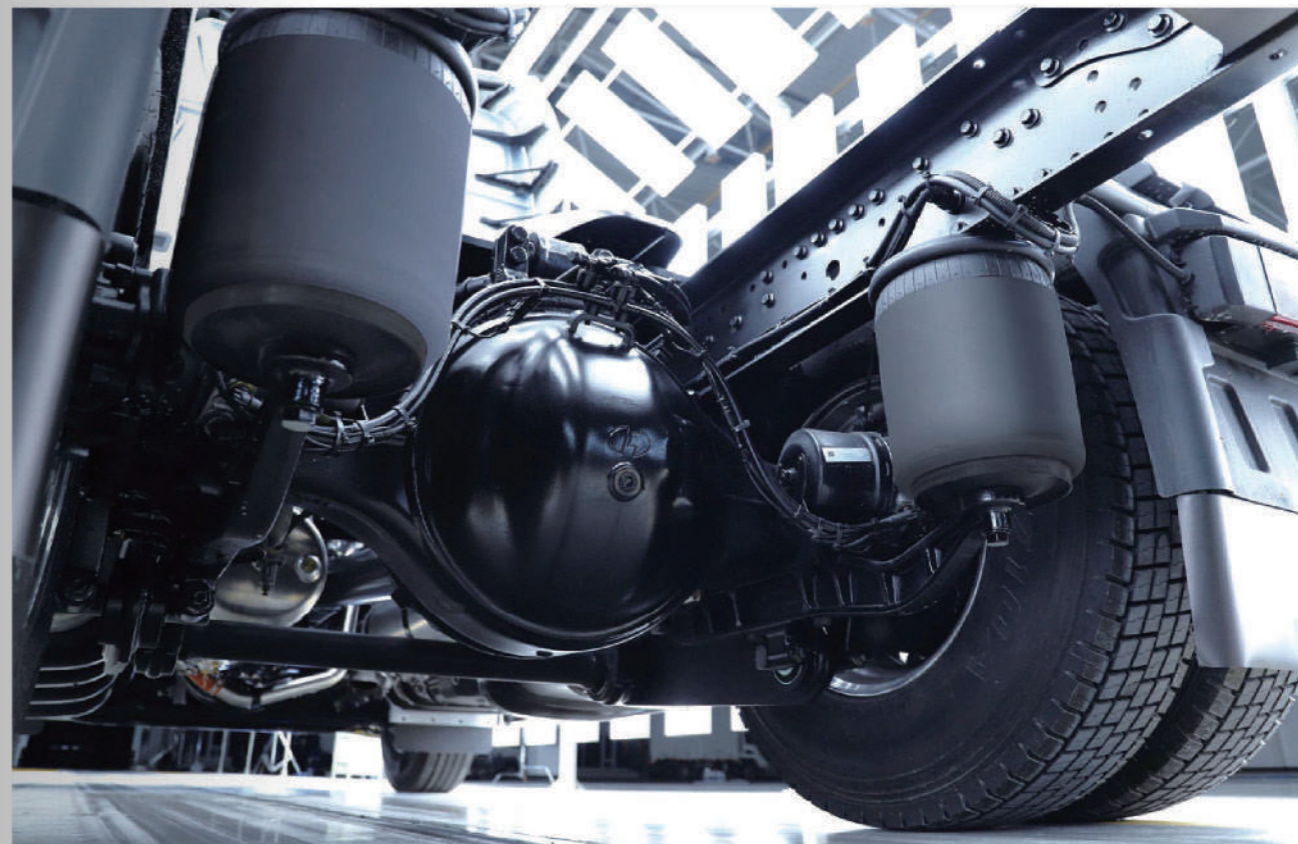



X6000 Tractor					
Drive		4×2	6×2	6×4	
GCW (t)		42	50	60	90
Main configuration	Cab	Type	Extended high roof, extended flat roof		
		Suspension	Four-point air suspension		
		Seat	Ventilation and heating air seats		
		Air conditioner	Electric automatic constant temperature AC		
	Engine	Model	WP13, M13, Z14, 15N, X15D		
		Emission standard	Euro III-VI		
		Power range (Ps)	480-600		
		Torque (N·m)	2400-2750		
	Transmission	Model	AMT (12/16), MT (16)		
		Torque (N·m)	2200-2800		
	Axle	Front axle	7.3t		9.5t
		Rear axle	13t single-stage		13t double-stage
Chassis	Dimension (mm)	(940-850)×270(single-layer 8)		(970-850)×300 (8+5)	
	Wheel base (mm)	3800	3450+1350	3175+1400	3450+1350
	Fuel tank	600L-1380L aluminum alloy		600L-1000L aluminum alloy	
	Tire	295/80R22.5, 315/70R22.5, 315/80R22.5		11R22.5, 12R22.5, 295/80R22.5, 315/70R22.5, 315/80R22.5	
	Suspension	Leaf spring suspension, air suspension		Leaf spring suspension	
	Saddle	L50/JOST 50		JOST 90	
Applicable condition	Application	Long distance logistics, standard load transportation		Medium to short distance transportation, heavy transportation	
	Economic/Max speed (km/h)	70-90/120	65-80/100	50-80/90	45-65/90
Other configurations		Electric flipping cab, power glass lift, Electric heated rearview mirror, multi-function steering wheel, ventilated heated air seat, Hande maintenance-free axle, 220Ah maintenance-free battery, EBS + ESC, 360° vision system, 10-inch LCD display, tire pressure monitoring system, driver fatigue monitoring system, individual warm air, folding desktop, 42L onboard refrigerator, 1200W power inverter, power sunroof, AEB, ACC, LDWS+FCWS, aluminum alloy rim, push button start, load self-weighting axle, centralized lubrication of saddle, SHACMAN Telematics			

Engine					
Emission Standards	Model	Engine Capacity (L)	Power (Ps)	Maximum Torque (N·m)	Rated Speed (rpm)
Euro VI	15N	14.5	530	2500	1900
	X15D	14.5	600	2800	1800
	Z14	14	480-600	2400-2750	1800
Euro V	M13	13	480-560	2400-2600	1800
	WP13	13	480-550	2400-2550	1900
Euro III	M13	13	480-560	2400-2600	1800

Transmission					
Shift Mode	Model	Gear Position	Torque Range (N·m)	Overdrive Gear/Direct Drive Gear	Speed ratio range
AMT	S16AO	16/2	2400-2800	Overdrive	14.13-0.83; R13.00/10.77
	S16AD	16/2	2400-2800	Direct Drive	17.09-1.00; R15.73/13.00
	Z12AD	12/2	2400-2800	Direct Drive	16.69-1.00; R15.54/12.03
	E12AO	12/2	2650	Overdrive	14.43-0.77; R16.92/12.95
MT	Z16MO	16/1	2200-2500	Overdrive	13.80-0.84; R12.92
	S12MO	16/2	2200-2400	Overdrive	12.098-0.779; R11.572/2.594



Crystal White

Granite Grey

Aquamarine Blue

Sapphire Blue

Emerald Green

Ruby Red

