

SHANTUI

L36-B3

Wheel Loader



Engine model	Weichai WP6G125E201
Total power	92kW/2000rpm
Operating weight	10,300kg
Bucket capacity	1.7m ³

VALUE THAT WORKS

L36-B3 TECHNICAL PARAMETERS

ENGINE

Emission standard	Stage II
Brand	Weichai
Model	WP6G125E201
Rated power	92kW/2000rpm
Max. torque	540N · m
Displacement	6.75L
No. of cylinders	6
Exhaust mode	Turbocharging

PERFORMANCE OF LOADER

Rated load	3000kg
Max. breakout force	105kN
Unloading angle	45°
Unloading height	3057mm
Unloading distance	906mm
Height of boom pin shaft	3975mm
Digging depth	30mm
Bucket capacity	1.7m ³
Operating weight	10300kg

TRANSMISSION SYSTEM

Transmission type	Fixed-shaft
Torque converter	Single-stage, single-phase, 3-element
Max. travel speed (forward)	37km/h
Max. travel speed (backward)	28km/h
Forward gear	4
Reverse gear	2

DRIVE AXLE

Type of front axle differential lock	Common differential
Type of rear axle differential lock	Common differential
Swing angle of rear axle	±12°

STEERING SYSTEM

Type of steering system	Articulated type
Steering system pressure	14Mpa

BRAKE SYSTEM

Service brake type	Caliper disc brake
Service brake mode	Air-over-oil brake
Parking brake type	Flexible shaft control
Parking brake mode	Mechanical caliper disc type

TIRE

Tire model	175-25/12/12PR
------------	----------------

HYDRAULIC SYSTEM

Type of working pump	Gear pump
System pressure	16Mpa
Boom lifting time	5.1S
Total cycle time	9s

OIL CAPACITY

Fuel tank	150L
Hydraulic oil tank	160L
Engine oil	16L
Drive axle (single side)	18/18L
Transmission	38L
Antifreeze	26kg

OVERALL DIMENSIONS

A Vehicle length	7187mm
B Vehicle width	2454mm
C Vehicle height	3235mm
D Wheelbase	2700mm
E Wheel track	1856mm
F Min. ground clearance	350mm
G Steering angle	36°
H Turning radius (outer side of front tire)	5325mm
I Turning radius (front tire center)	5100mm
J Turning radius (outer edge of bucket)	5920mm

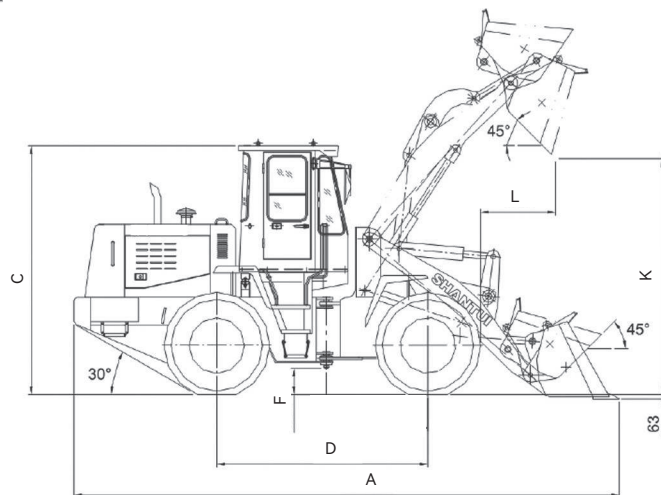
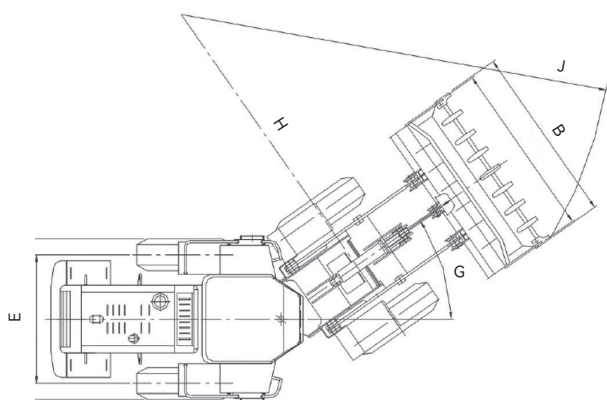

* THE SPECIFICATIONS ARE SUBJECT TO CHANGE WITHOUT NOTICE. THE PICTURES MAY INCLUDE OPTIONAL CONFIGURATION. THE ACTUAL COLOR & APPEARANCE OF THE PRODUCT MAY DIFFER FROM WHAT IS SHOWN.



Shantui Social

SHANTUI CONSTRUCTION MACHINERY CO., LTD.

ADD: NO. 58, G327 HIGHWAY, HI-TECH ZONE, JINING CITY, SHANDONG, CHINA

TEL: +86-537-2909369 FAX: +86-537-2311219

EMAIL: trade@shantui.com WEB: www.shantui.com

SHANTUI
VALUE THAT WORKS