



SHANTUI

L58K-B5

Wheel Loader

Engine Model: Weichai WD10G220E23
Gross Power: 162kW@2000rpm
Operating Weight: 18,370kg
Bucket Capacity: 3.0m³

Performance and comfort you can feel,
Reliability you can trust!

L58K-B5 SPECIFICATIONS

ENGINE

Emission Regulation	Tier 2 / Stage II
Make	Weichai
Model	WD10G220E23
Rated Power	162 kW (220 hp) @ 2,000 rpm
Max Torque	900 N · m
Displacement	9.726 L
Number of Cylinders	6
Aspiration	Turbocharged

LOADER ARM PERFORMANCE

Tipping Load - Full Turn	11000 kg
Bucket Breakout Force	185 kN
Maximum Dump Angle at Full Height	45°
Dump Clearance at Full Height Discharge	3050 mm
Dump Reach at Full Height Discharge	1185 mm
Maximum Hinge Pin Height	4101 mm
Maximum Digging Depth, Bucket Level	116 mm
Bucket Capacity	3.0 m ³
Operating Weight	18370kg

TRANSMISSION

Transmission Type	Planetary, power shift
Torque Converter	Single stage, four elements
Maximum Travel Speed, fwd	39 km/h
Maximum Travel Speed, rev	15 km/h
Number of Speeds, fwd	2
Number of Speeds, rev	1

AXLES

Differential Front Type	Conventional
Differential Rear Type	Conventional
Axle Oscillation	±12°

STEERING

Steering Configuration	Articulated
Steering System Pressure	16 Mpa

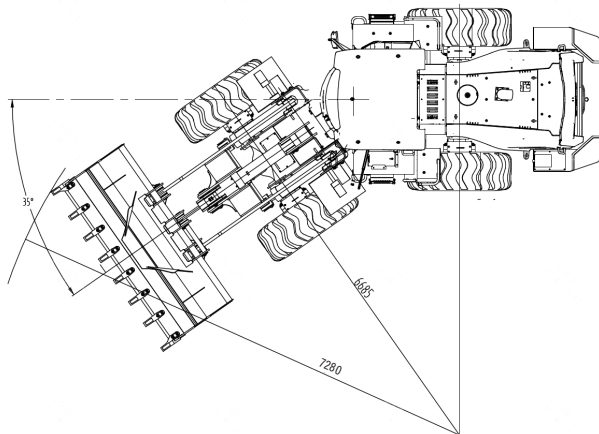

BRAKES

Service Brake Type	Caliper disc brake
Service Brake Actuation	Air over Hydraulic
Parking Brake Type	Flexible shaft control
Parking Brake Actuation	Mechanical

TIRES

Tire Size	23.5-25 L3
-----------	------------

HYDRAULIC SYSTEM

Main Pump Type	Gear
Main Relief Pressure	18 Mpa
Raise time	5.1 S
Total Cycle Time	10.5 S

SERVICE CAPACITY

Fuel Tank	300 L
Hydraulic oil Tank	170 L
Engine Oil	21 L
Axles, each	27X2 L
Transmission	45 L
Cooling System	80 kg

DIMENSIONS

Length	8300 mm
Width	3066 mm
Height	3450 mm
Wheelbase	3300 mm
Wheel Tread	2250 mm
Ground Clearance	430 mm
Turn Angle, Either Side	±35°
Turning Radius, Outside of Tire	6685 mm
Turning Radius, Center of Tire	6385 mm
Turning Radius, Bucket Carry	7280 mm

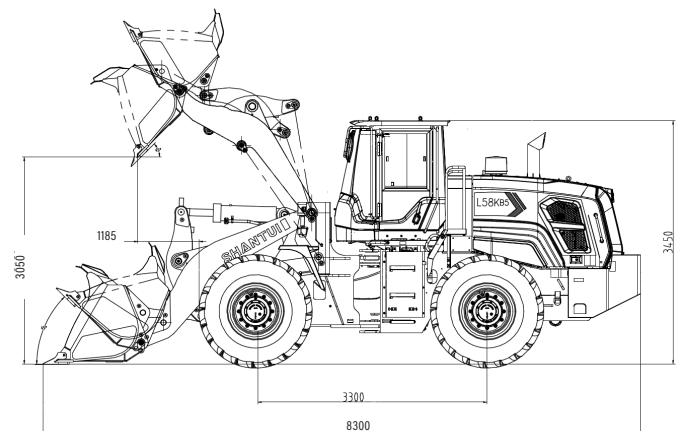

* THE SPECIFICATIONS ARE SUBJECT TO CHANGE WITHOUT NOTICE. THE PICTURES MAY INCLUDE OPTIONS. THE ACTUAL COLOR & APPEARANCE OF THE PRODUCT MAY DIFFER FROM WHAT IS SHOWN.



Shantui Social

SHANTUI CONSTRUCTION MACHINERY CO., LTD.
 ADD: No. 58, G327 Highway, Jining City, Shandong, CHINA
 TEL: +86-537-2909369
 FAX: +86-537-2311219
 EMAIL: trade@shantui.com
 WEB: www.shantui.com

SHANTUI
 LET'S MAKE CONSTRUCTION EASIER