

SHANTUI

L76-C5

Wheel Loader



Engine Model: Weichai Engine WP10
Gross Power: 210kW@2200rpm
Operating Weight: 24,800kg
Bucket Capacity: 4.5m³

Performance and comfort you can feel,
Reliability you can trust!

L76-C5 SPECIFICATIONS

ENGINE

Emission Regulation	Tier 3 / Stage III
Make	Weichai engine
Model	WP10G286E301
Rated Power	210kW @ 2200 rpm
Max Torque	1400N·m
Displacement	9.7L
Number of Cylinders	6
Aspiration	Turbocharged

LOADER ARM PERFORMANCE

Tipping Load - Full Turn	160KN
Bucket Breakout Force	215KN
Maximum Dump Angle at Full Height	45°
Dump Clearance at Full Height Discharge	3540 mm
Dump Reach at Full Height Discharge	1220 mm
Maximum Hinge Pin Height	4800 mm
Maximum Digging Depth, Bucket Level	100 mm
Bucket Capacity	4.5m ³
Operating Weight	24800kg

TRANSMISSION

Transmission Type	Electronically controlled fixed shaft
Torque Converter	Single stage, three elements
Maximum Travel Speed, fwd	39.4 km/h
Maximum Travel Speed, rev	25.8 km/h
Number of Speeds, fwd	4
Number of Speeds, rev	3

AXLES

Differential Front Type	-
Differential Rear Type	-
Axle Oscillation	±12°

STEERING

Steering Configuration	Articulated
Steering System Pressure	20 Mpa

BRAKES

Service Brake Type	four-wheel dual-loop disc brake system
Service Brake Actuation	Air over Hydraulic
Parking Brake Type	shoe brake on gearbox output shaft
Parking Brake Actuation	Air brake

TIRES

Tire Size	26.5-25
-----------	---------

HYDRAULIC SYSTEM

Main Pump Type	Constant variable dual pump confluence
Main Relief Pressure	25 Mpa
Raise time	5.5 S
Total Cycle Time	10.1 S

SERVICE CAPACITY

Fuel Tank	365 L
Hydraulic oil Tank	185L
Engine Oil	21 L
Axles, each	43L
Transmission	46 L
Antifreeze	80 L

DIMENSIONS

Length	9445 mm
Width	3236 mm
Height	3670 mm
Wheelbase	3550 mm
Wheel Tread	2380 mm
Ground Clearance	480 mm
Turn Angle, Either Side	38°
Turning Radius, Outside of Tire	6345 mm
Turning Radius, Center of Tire	6170 mm
Turning Radius, Bucket Carry	7560 mm

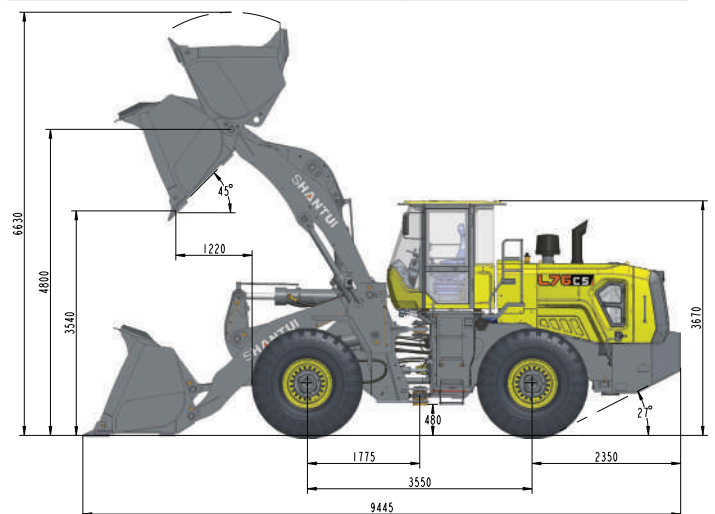
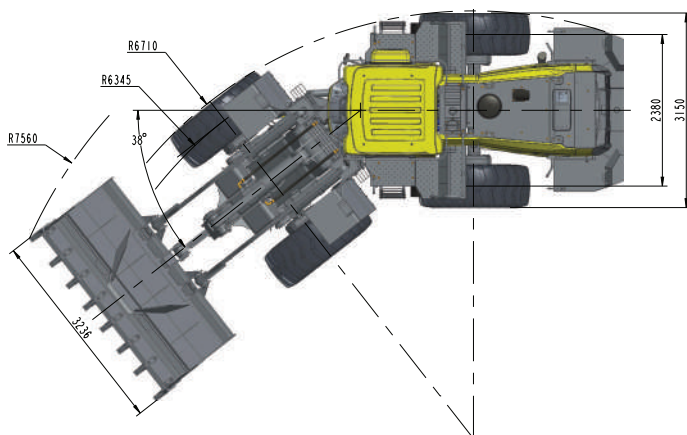

* THE SPECIFICATIONS ARE SUBJECT TO CHANGE WITHOUT NOTICE. THE PICTURES MAY INCLUDE OPTIONS. THE ACTUAL COLOR & APPEARANCE OF THE PRODUCT MAY DIFFER FROM WHAT IS SHOWN.



Shantui Social

SHANTUI CONSTRUCTION MACHINERY CO., LTD.
 ADD: No. 58, G327 Highway, Jining City, Shandong, CHINA
 TEL: +86-537-2909369
 FAX: +86-537-2311219
 EMAIL: trade@shantui.com
 WEB: www.shantui.com

SHANTUI
 LET'S MAKE CONSTRUCTION EASIER