

SHANTUI

L98K-C5

Wheel Loader



| | |
|------------------|-------------------|
| Engine model | Cummins QSM11 |
| Total power | 298kW/2100rpm |
| Operating weight | 34,500kg |
| Bucket capacity | 5.6m ³ |

VALUE THAT WORKS

L98K-C5 TECHNICAL PARAMETERS

ENGINE

| | |
|-------------------|-----------------|
| Emission standard | Stage III |
| Brand | Cummins |
| Model | QSM11 |
| Rated power | 298kW/2100rpm |
| Max. torque | 1890N-m/1400rpm |
| Displacement | 10.8L |
| No. of cylinders | 6 |
| Exhaust mode | Turbocharging |

PERFORMANCE OF LOADER

| | |
|--------------------------|-------------------|
| Rated load | 9800kg |
| Max. breakout force | 258kN |
| Unloading angle | 45° |
| Unloading height | 3410mm |
| Unloading distance | 1350mm |
| Height of boom pin shaft | 4695mm |
| Digging depth | 100mm |
| Bucket capacity | 5.6m ³ |
| Operating weight | 34500kg |

TRANSMISSION SYSTEM

| | |
|------------------------------|---------------------------------------|
| Transmission type | Electronic control fixed-axis gearbox |
| Torque converter | Single-stage, single-phase, 3-element |
| Max. travel speed (forward) | 37.25km/h |
| Max. travel speed (backward) | 26.12km/h |
| Forward gear | 4 |
| Reverse gear | 3 |

DRIVE AXLE

| | |
|--------------------------------------|--|
| Type of front axle differential lock | Hydraulically controlled differential lock |
| Type of rear axle differential lock | - |
| Swing angle of rear axle | ±12° |

STEERING SYSTEM

| | |
|--------------------------|-----------------------|
| Type of steering system | Traffic amplification |
| Steering system pressure | 21Mpa |

BRAKE SYSTEM

| | |
|--------------------|---------------------------------------|
| Service brake type | Dual-circuit full hydraulic wet brake |
| Service brake mode | - |
| Parking brake type | Hydraulic caliper disc brake |
| Parking brake mode | - |

TIRE

| | |
|------------|---------|
| Tire model | 29.5-25 |
|------------|---------|

HYDRAULIC SYSTEM

| | |
|----------------------|-----------------------------|
| Type of working pump | Variable displacement pumps |
| System pressure | 26MPa |
| Boom lifting time | 5.7s |
| Total cycle time | 10.7s |

OIL CAPACITY

| | |
|--------------------------|------|
| Fuel tank | 500L |
| Hydraulic oil tank | 290L |
| Engine oil | 24L |
| Drive axle (single side) | 65L |
| Transmission | 42L |
| Antifreeze | 45L |

OVERALL DIMENSIONS

| | |
|---|--------|
| A Vehicle length | 9900mm |
| B Vehicle width | 3570mm |
| C Vehicle height | 3890mm |
| D Wheelbase | 3800mm |
| E Wheel track | 2420mm |
| F Min. ground clearance | 428mm |
| G Steering angle | ±40° |
| H Turning radius (outer side of front tire) | 6830mm |
| I Turning radius (front tire center) | 6430mm |
| J Turning radius (outer edge of bucket) | 7774mm |

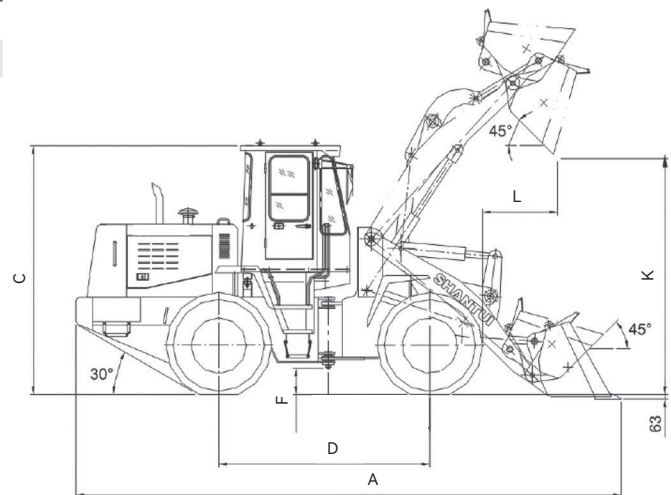
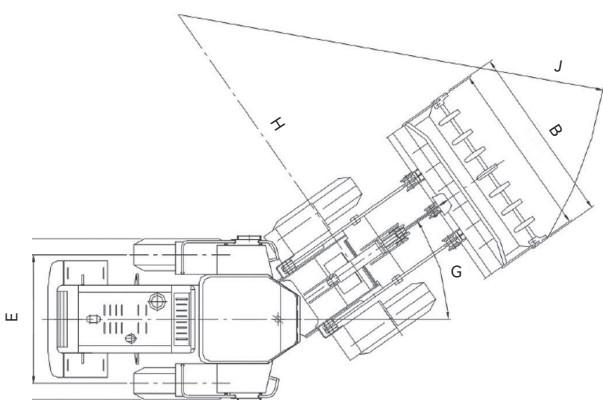

* THE SPECIFICATIONS ARE SUBJECT TO CHANGE WITHOUT NOTICE. THE PICTURES MAY INCLUDE OPTIONAL CONFIGURATION. THE ACTUAL COLOR & APPEARANCE OF THE PRODUCT MAY DIFFER FROM WHAT IS SHOWN.



Shantui Social

SHANTUI CONSTRUCTION MACHINERY CO., LTD.

ADD: NO. 58, G327 HIGHWAY, HI-TECH ZONE, JINING CITY, SHANDONG, CHINA

TEL: +86-537-2909369 FAX: +86-537-2311219

EMAIL: trade@shantui.com WEB: www.shantui.com

SHANTUI
VALUE THAT WORKS